

镜头参数 (Parameter of Lens)

型号 (Model) :	ACL-M12-2.1 (MP)			
分辨率 (Resolution)	Megapixel			
像面尺寸 (Image format)	Φ6.3			
焦距 (Focal length)	2.1mm			
通光孔径 (Aperture)	F2.1			
接口 (Mount)	M12×0.5			
视场角 (Field Angle) D×H×V(°)	θ	1/2.7	1/3	1/4
	D	195	178	128
	H	155	139	102
	V	114	102	75
畸变 (Optical Distortion)	-97%			
主光束入射角 (CRA)	≤8.8°			
最近物距 (M. O. D.)	0.15m			
外形尺寸 (Dimension)	Φ16×10.55mm			
重量 (Weight)	5±1g			
法兰后焦距 (Flange BFL)	/			
光学后焦距 (BFL)	4.53mm (in filter)			
机械后焦距 (MBF)	3.97mm (in filter)			
振动等级 (Vibration Standard)	Sine Wave*2H*50HZ			
防水等级 (Waterproof Standard)	65KPA			
日夜共焦 (IR Correction)	NO			
操作方法 (Operation)	光圈 (Iris)	固定光圈 (Fixed)		
	聚焦 (Focus)	手动聚焦 (Manual)		
	变焦 (Zoom)	/		
防护等级 (Ingress Protection)	IP68			
工作温度 (Operating temperature)	-40℃~+105℃			

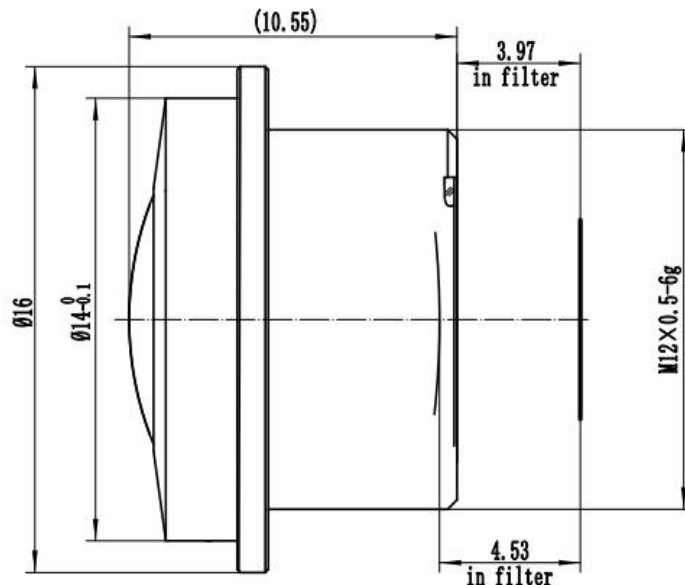

尺寸 (Size)



尺寸公差 Size tolerance (mm) 0-10±0.05

10-30±0.10

角度公差Angle tolerance

$\pm 2^\circ$